



# WIPE UP

The Future of Personal Hygiene.

**On-demand clean. • No waste. • No compromise.**

# Hygiene Today is Broken



## Toilet Paper

Not truly clean.  
Rough, dry friction.



## Wet Wipes

Wasteful and expensive. Not  
flushable, causing global plumbing  
infrastructure damage.

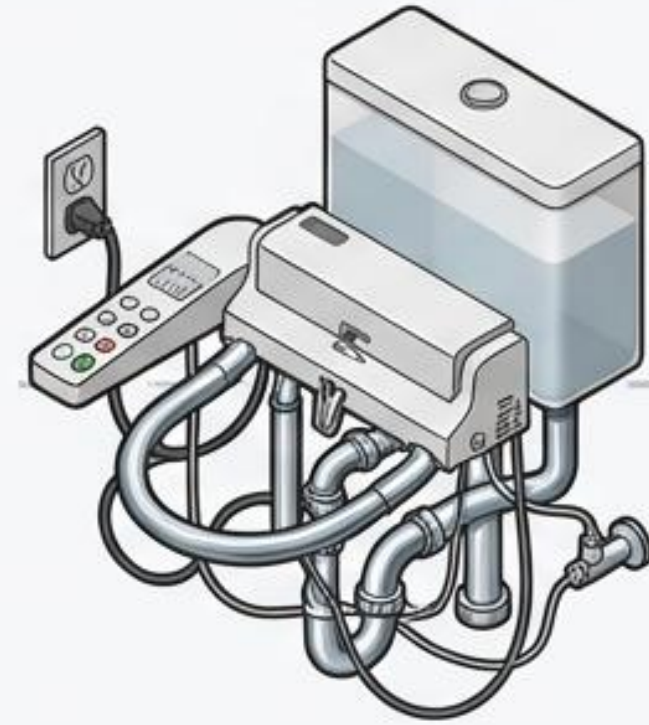

## Bidets

Complex and not scalable.  
Requires plumbing, electricity, and  
high upfront installation costs.

Consumers are forced to compromise between clean, convenience, and sustainability.

People don't want products.  
They want to feel clean.

**FAST. EFFORTLESS. RELIABLE.**

No current solution delivers all three. We are upgrading a daily global habit with a simple, scalable solution.

# A New Category in Personal Hygiene

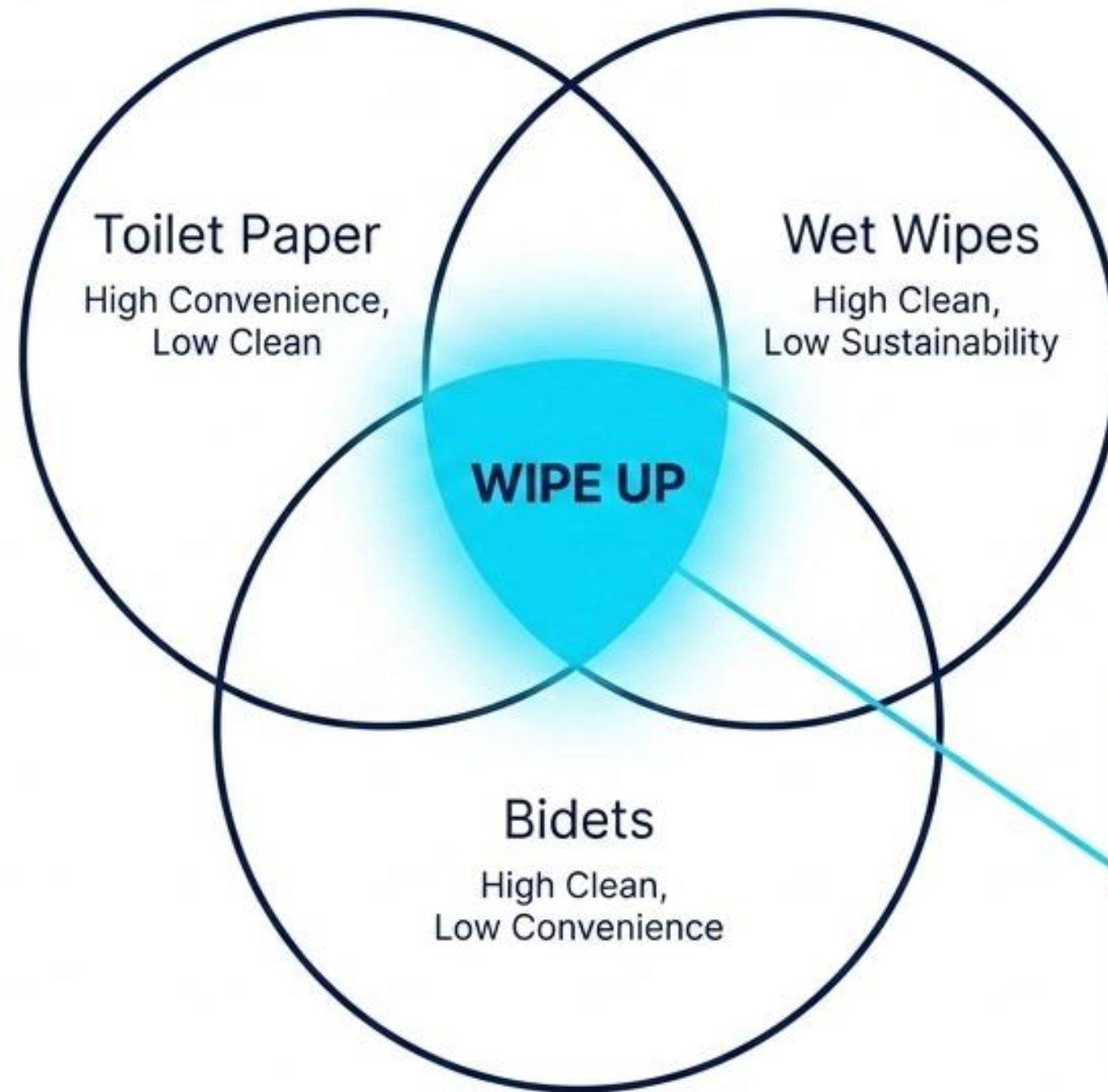

**The missing layer in a daily routine.**

Bridges the gap with zero compromises.

# Re-inventing the Experience

- ✓ Dry or wet paper on demand.
- ✓ No plumbing required.
- ✓ No electricity required.
- ✓ No waste.

---

**Precision cleaning, instantly.**



# Designed for Real Life

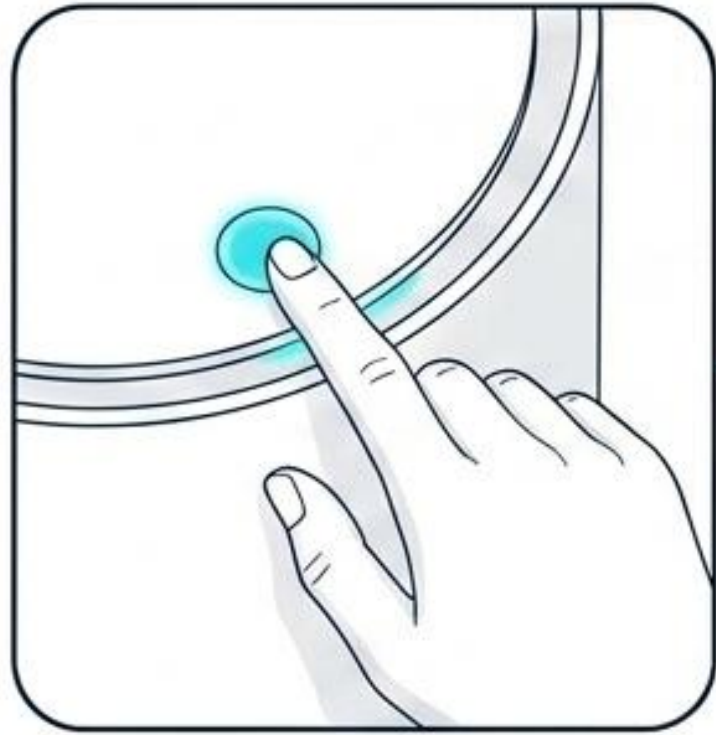

**01.** One-touch activation.

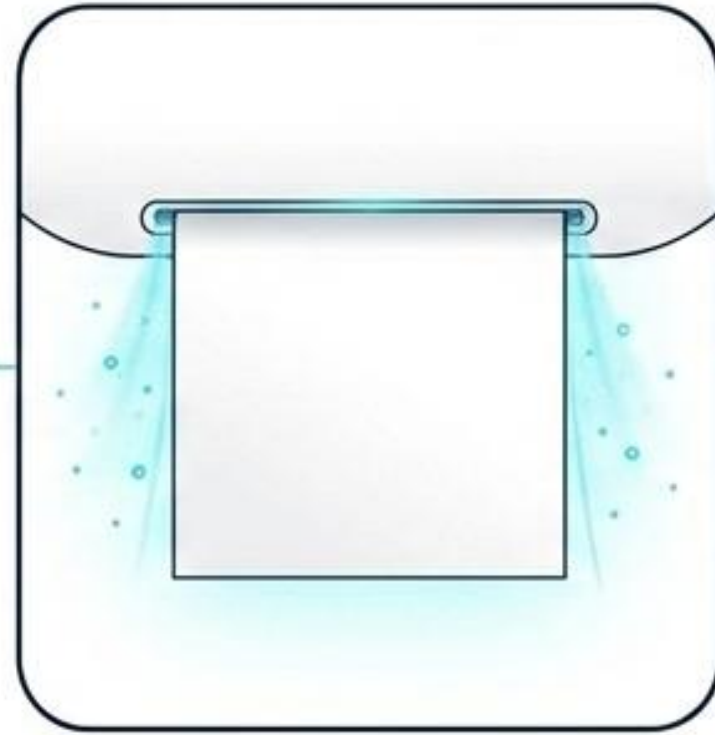

**02.** Instant wet or dry output.

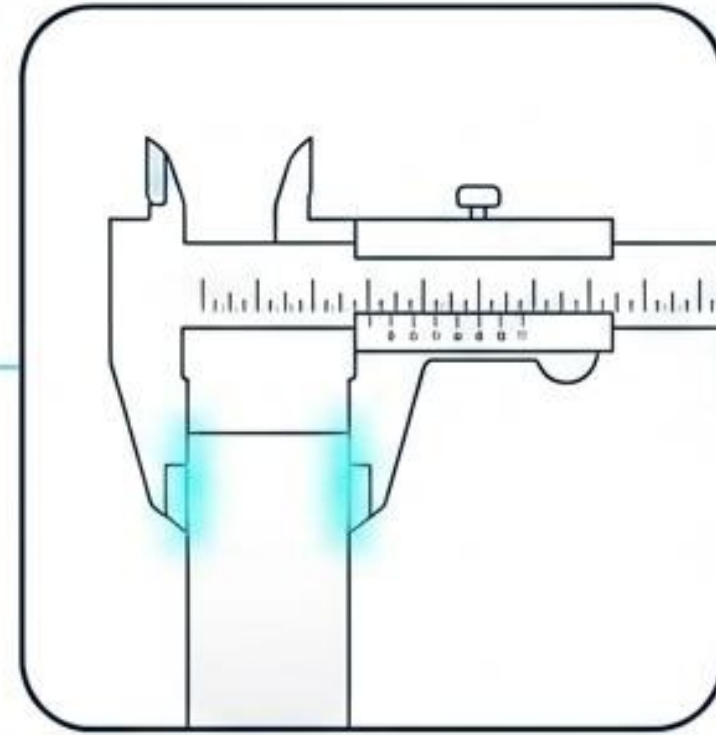

**03.** Controlled usage every time.



**04.** Clean, minimal, intuitive.

**From routine to experience.**

# Engineered for Simplicity

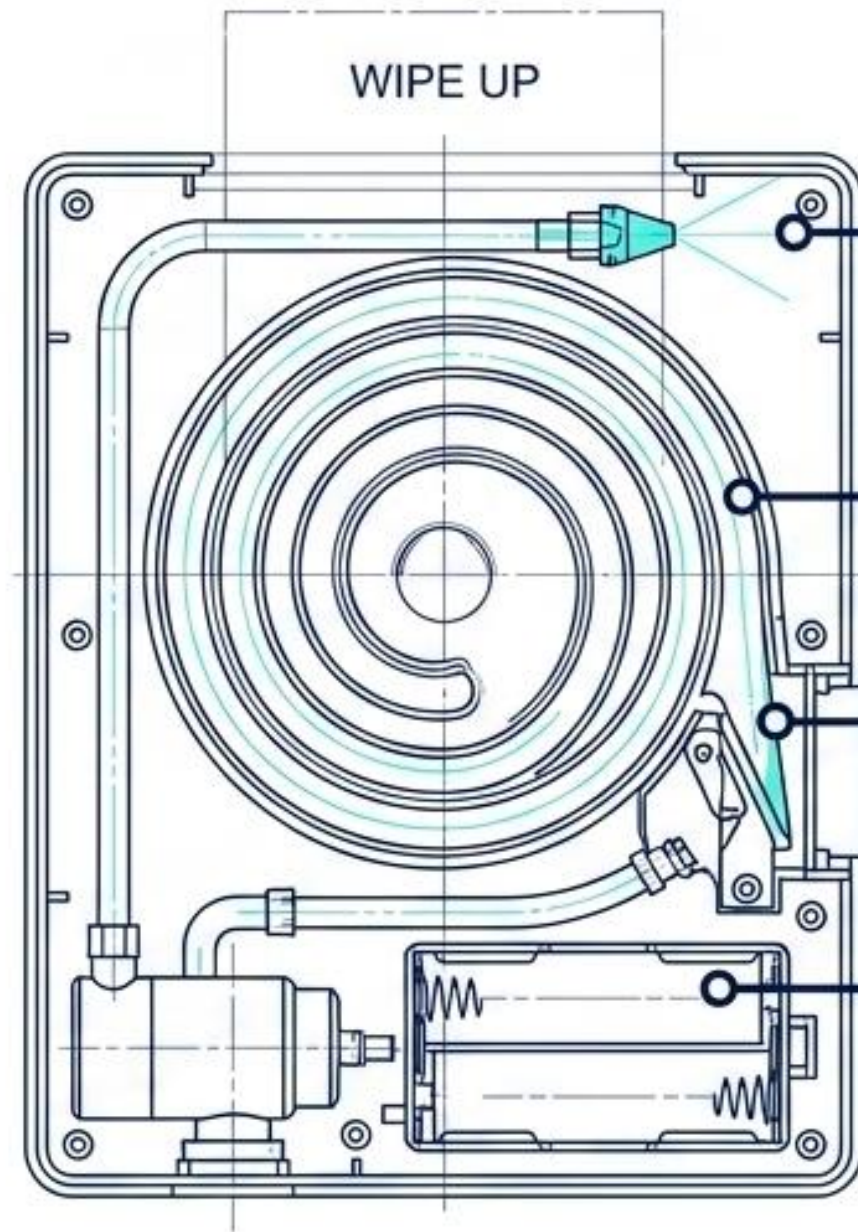

## Micro-Mist Technology

30-50 micron droplet spray precisely targeting the paper mid-section.

## Spiral Path

450mm internal rail path with 2 cm dry margins to prevent tearing.

## Ceramic Blade

23-degree cutting angle synchronized via MCU encoder ( $\pm 2$  mm accuracy).

## Power Efficiency

Operates 8-12 months on just 2 standard AA lithium batteries.

# A System, Not a Device



**Built for continuous consumption.**

# Built to Win: The Competitive Edge

## The Lock-in Mechanism

Patent 327637 (Accelerated track).



## How it Works

Proprietary asymmetric hollow sleeve mechanically disables standard TP bypass. The system will not output wet mist without a recognized original roll.



## Defensibility

High switching costs, absolute consumer lock-in, and zero direct equivalents in the market.



## Asymmetric Sleeve Interface

Proprietary Asymmetric Hollow Sleeve

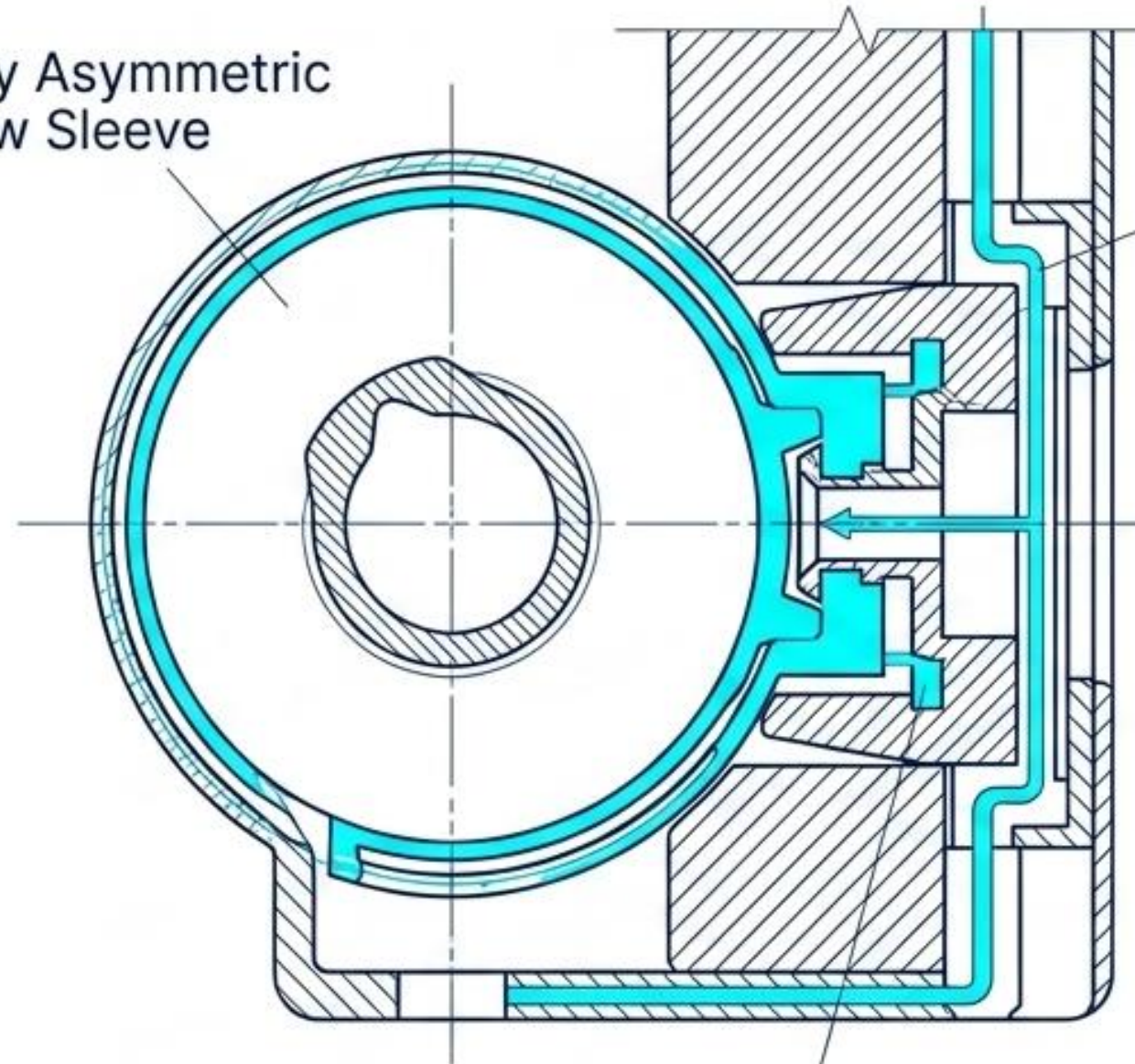

Standard TP Bypass Disabled

Wet Mist Activation Point  
(Requires Recognized Roll)

# A Massive, Recurring Market



**WIPE UP sits at the intersection of all three, capturing value across \$90B+ in recurring global demand.**

# Starting Where Adoption is Fastest

## Phase 1: Israel

15-20% projected adoption. Serves as the ultimate pilot/validation market due to high bidet/wipe familiarity.

## Phase 2: United States

8-10% projected adoption. Massive scale via Amazon; impulse buy for renters lacking plumbing options.

## Phase 3: Europe

10% projected adoption. Driven by sustainability demands and flushability regulations.

## Phase 4: Japan & Gulf States

Premium positioning and high-tech adoption potential.



# One Platform. Multiple Use Cases.

## Core Concept: Personal Hygiene

Replacing adult TP and flushable wipes.

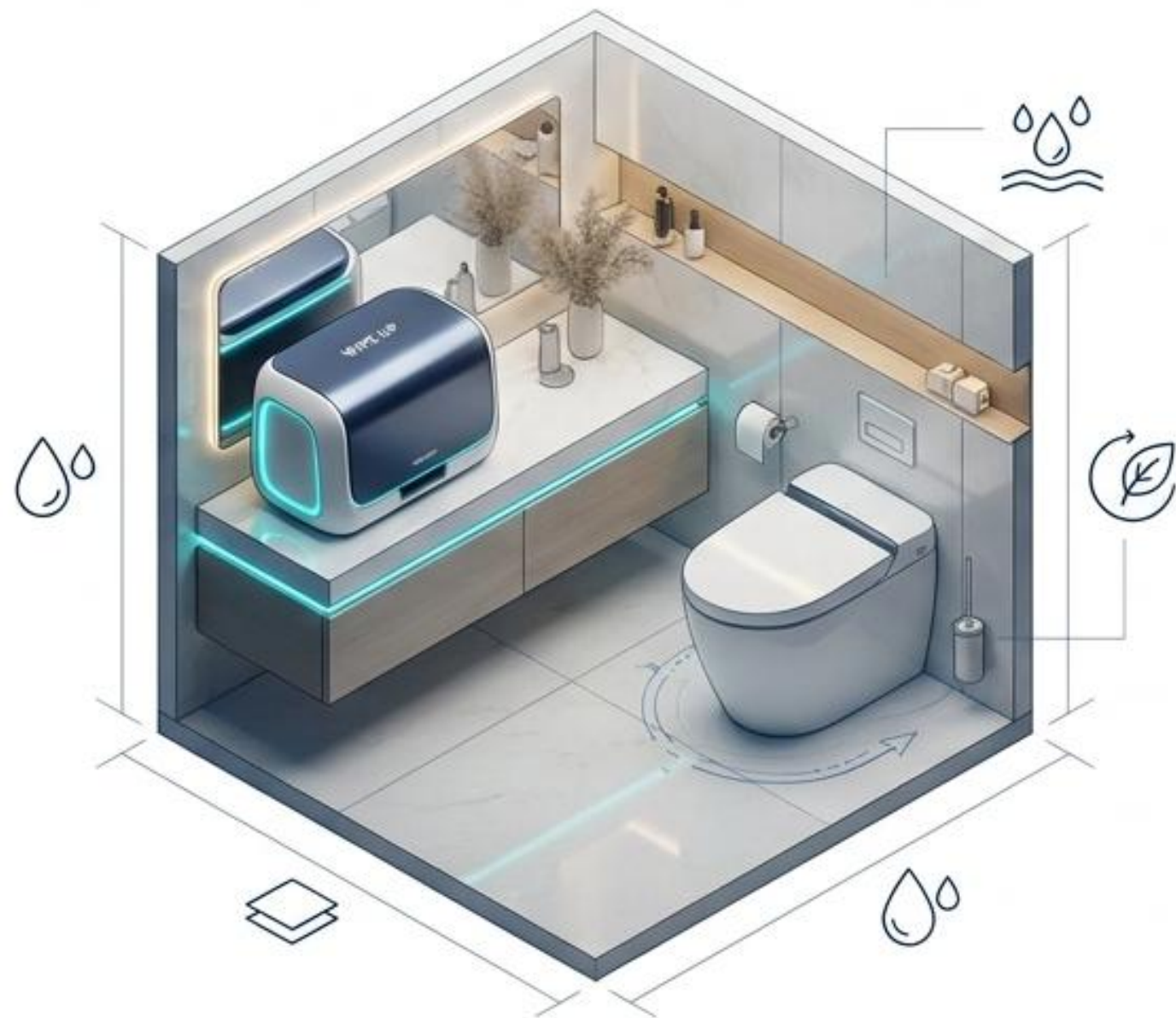

## Expansion Concept: Baby Care

Dedicated configuration for nurseries utilizing **hypoallergenic, alcohol-free formulas** and eliminating chemical wipe waste.



# Unit Economics & Recurring Revenue

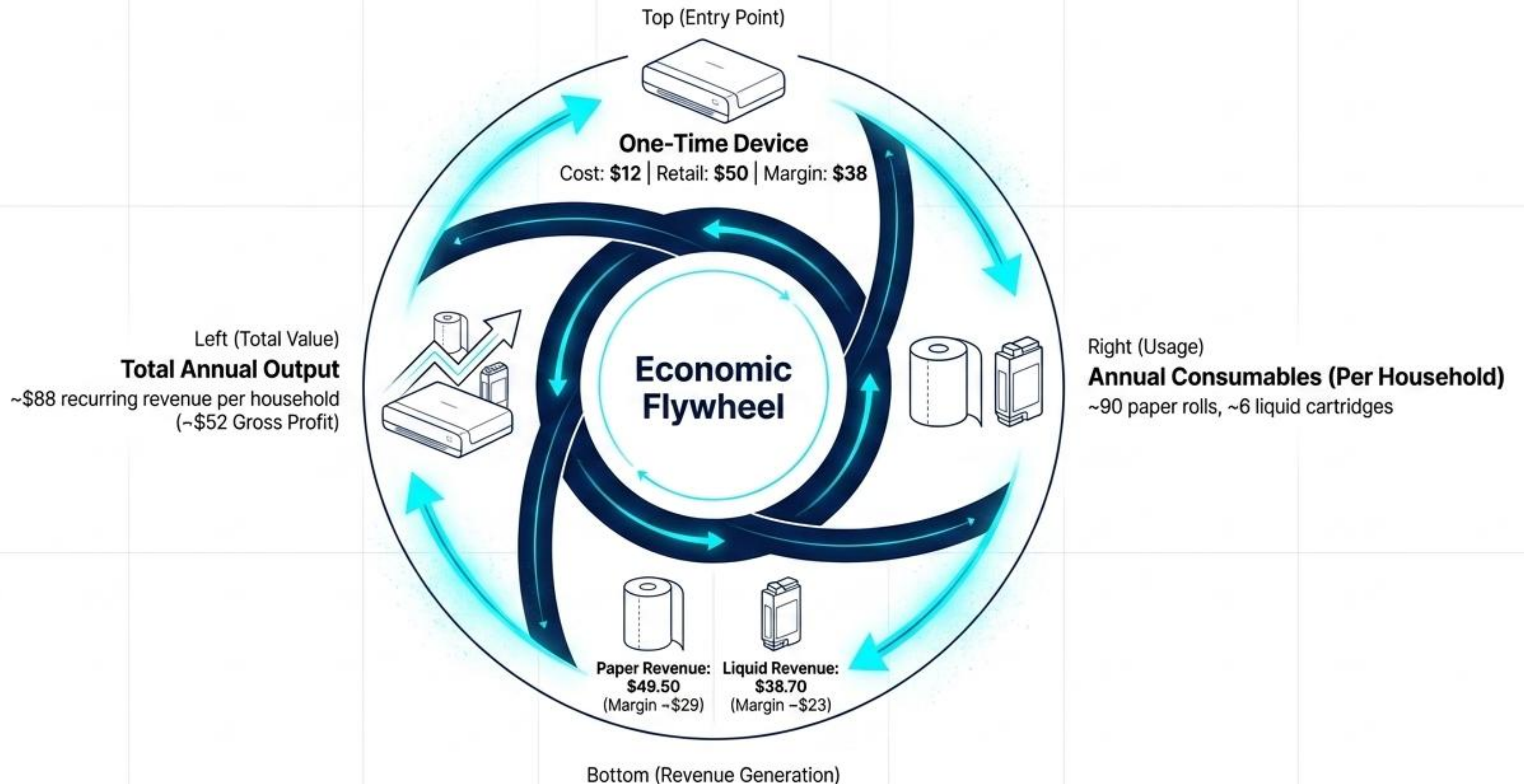

# Fast Entry Through Existing Players



## The Model: B2B2C

WIPE UP Technology  
& Hardware



## The Strategy: Partnerships

Established Toilet Paper  
brands and Hygiene  
companies (e.g.,  
Sano/Huggies equivalents)

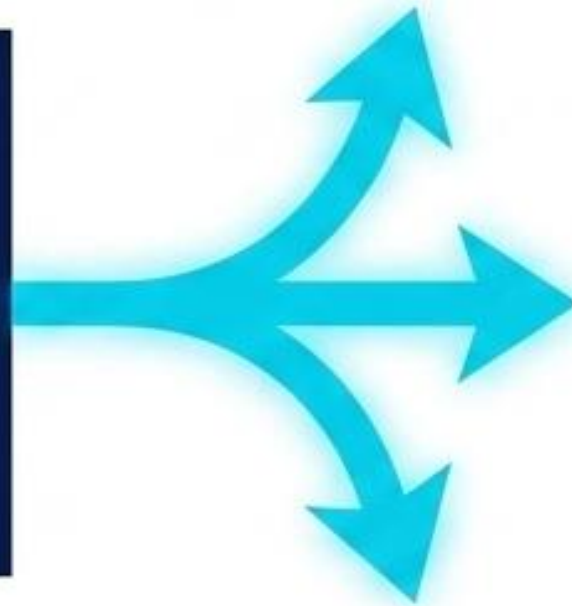

## The Win: Consumer Households

Leverage their existing retail,  
distribution networks, and  
shelf-space to rapidly deploy  
our proprietary hardware.

# From Concept to Execution



Full PRD 6.0 Completed.



Engineering architecture defined (Step files, BOM).



Patent 327637 filed (Accelerated Green Track).



Design and system validated.



Current Phase: Prototyping and tooling setup.



# The Smart Equity Behind WIPE UP



**Asher**

**Founder / VP Ops**

Global toiletries expert. Manages global supplier networks, paper mills, and market research.



**Avi**

**Partner (18%) / VP R&D & IT**

IT architecture. Manages digital infrastructure, app ecosystem, and technical specs.



**Shimon**

**VP Ops & Finance**

Supply chain operations, banking, and regulatory execution.

**Founder Commitment: Over 320,000 NIS in capital and sweat equity already invested to de-risk the core technology.**

# The Investment Opportunity

# Raising: 900,000 NIS | Pre-Money Valuation: 2.4M NIS

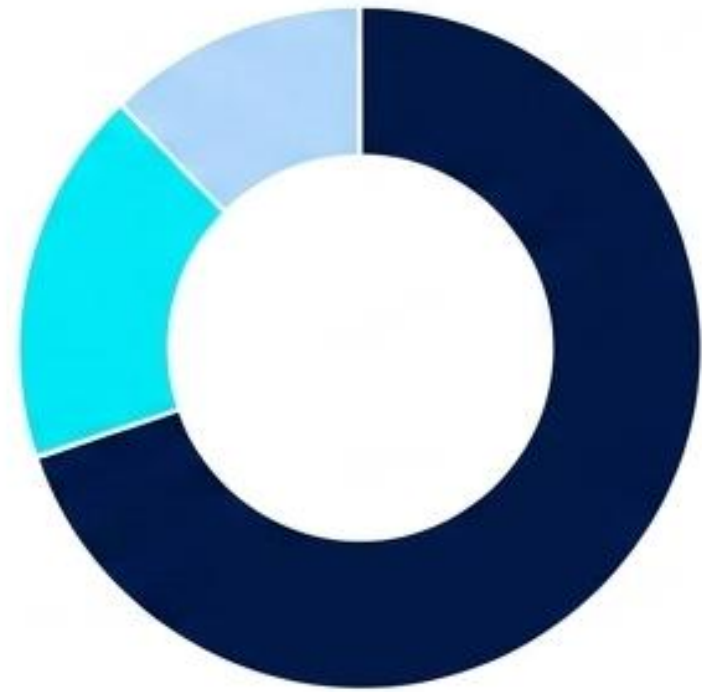
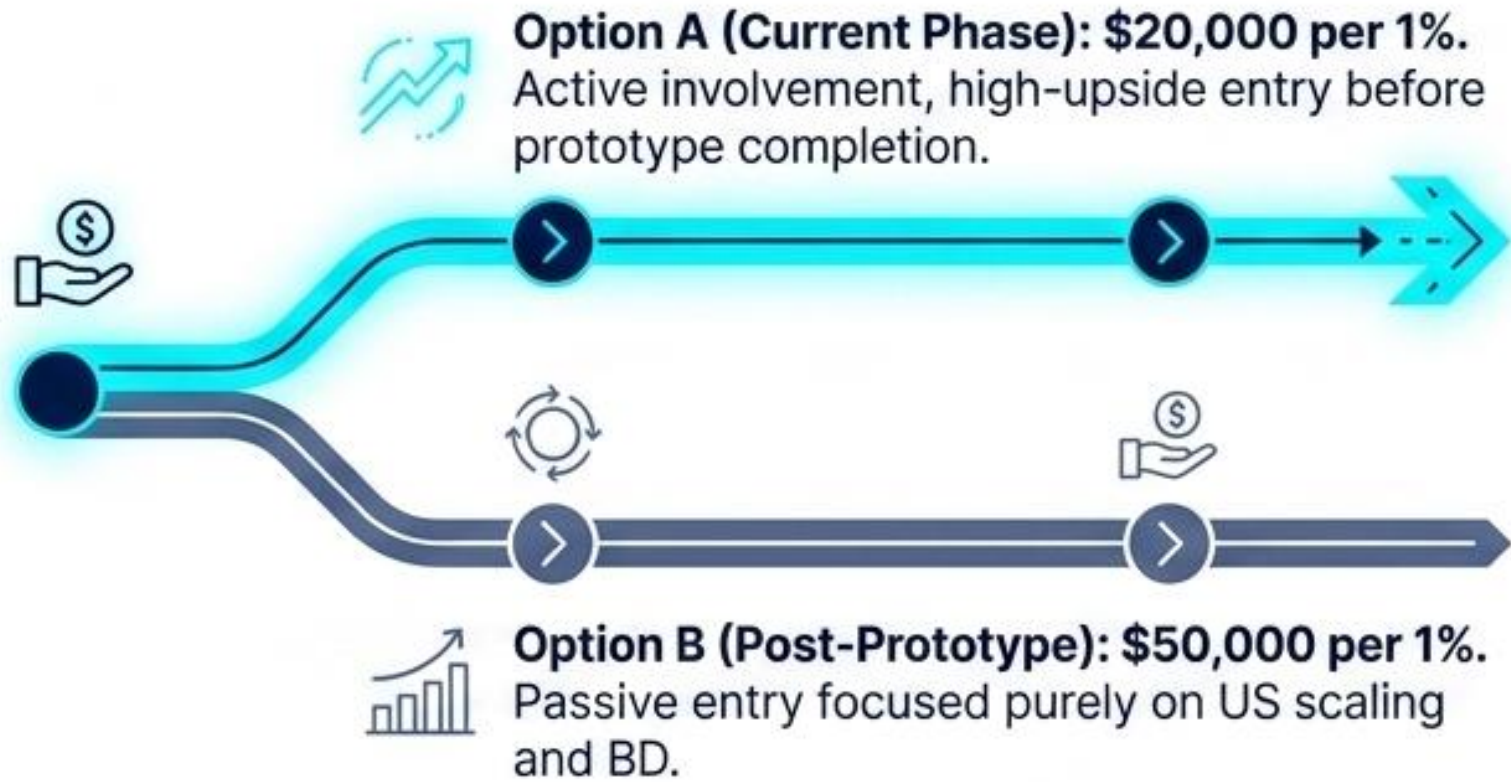

- **CAPEX**  
490k NIS  
(manufacturing/tooling)
- **R&D Prototype**  
120k NIS
- **IP/Patents**  
85k NIS



**We are not building a product.  
We are building a new global hygiene standard.**

The inevitable upgrade to a daily, universal human habit.